



rize

OWNER'S MANUAL



The **CLARITY** *Adjustable Bed Frame*

Model Number: RI-ASQ-A25-WW-SR-TL9-107

Serial Number: _____

(Place your serial number here for ready reference)

This product and all our bedding products are covered by one or more of the following issued and pending U.S. patents including Nos. 7448100, D657157, D663542, D657158, D657156, 8209801, 8209800, D663544, D663543 and other patents pending.

Not responsible for typographical errors. Photos are for illustration purposes only.

COPYRIGHT® 2017 CUSTOMATIC ADJUSTABLE BEDZ

Table of Contents

Safety Precautions.....	1
Parts List.....	3
Installation Guide.....	4
Remote Control Operation Guide	7
Synchronize Installation Guide	8
Troubleshooting	9
Warranty & Registration	10

Model Number: RI-ASQ-A25-WW-SR-TL9-107



Safety Precautions

ATTENTION!

IMPORTANT SAFETY INSTRUCTIONS.

PLEASE READ THESE INSTRUCTIONS THOROUGHLY BEFORE USING THIS PRODUCT.



ELECTRICAL SAFETY

Always unplug this adjustable bed frame from the electrical outlet before any cleaning or maintenance of the bed frame. To safely disconnect, make sure all controls are in the off position, then remove the plug from the outlet.

Keep cord away from heated surfaces. Keep air openings free of lint, hair and the like - never operate when air openings are blocked. Never drop or insert any object into any opening. Use only indoors.

Cease use of this bed frame and contact the Adjustable Bed base center for repair if: (1) it has a damaged cord or plug, (2) it is not working properly, (3) it has been dropped or damaged, or (4) it has been dropped into water.

GROUNDING SAFETY

To reduce the risk of electric shock, electrical fire, or faulty operation of this product, your Adjustable Bed features a polarized plug meant to be used only with a grounded electrical outlet. If this plug does not fit into your outlet, contact a qualified electrician to install a properly grounded outlet. Failure to use a properly grounded outlet for this product will compromise this important grounding safety feature. The use of adapters is not recommended unless the outlet is checked by a qualified electrician to ensure the proper grounding of the adapter. Please note: Unauthorized modifications to this product could void the electrical portion of your warranty.

WARRANTY WARNING!

This bed is specifically designed to require no maintenance by you, the user. Any opening or tampering with the control box, motors or remote controls (with the exception of the battery compartment if equipped) will result in a void of the warranty. Only those authorized may conduct repairs or part replacement on your adjustable bed.



FOR OPTIMAL SAFETY, YOUR ADJUSTABLE BED SHOULD BE PLUGGED INTO A SURGE PROTECTOR
(not supplied with this Adjustable Bed).

IN-HOME USE ONLY

This Adjustable Bed is designed exclusively for in-home use.

HOSPITAL DISCLAIMER: *It is NOT designed for hospital use and is NOT designed to meet hospital standards.*

Do not use this bed with TENT TYPE oxygen therapy equipment or use near explosive gases.

IMPORTANT SAFETY FEATURES

Weight fail safe feature: In the case that an overload of weight is placed on the head or foot mechanism, the control unit will automatically stop all functions. The control unit will automatically resume all functions 30 seconds after excess weight is removed.

WEIGHT RESTRICTIONS

The recommended weight limits on our adjustable beds are:

Twin/TXL/Split QN/Split CA King: 700 pounds, King/CA King/QN/Full/FXL: 850 pounds

Safety Precautions-cont'd

IMPORTANT SAFETY FEATURES cont'd

Locking caster feature: This Adjustable Bed may be equipped with special locking casters. For your safety, these casters will prevent bed movement when all casters are in the locked position. To lock casters, push down the safety latch on the caster. To resume product mobility, lift the safety latch up.

Please note: If your Adjustable Bed is positioned on a hard floor surface such as hardwood or tile, it is strongly recommended that rubber caster cups or carpet squares are placed under the casters in addition to locking them in place. Casters will not roll when locked, but may slide on an uncarpeted surface.

RADIO FREQUENCY IS 433.92 MHZ.

FCC compliance device complies with part 15 of the FCC Rules. Operation is subject to the following two conditions: (1) This device may not cause harmful interference, and (2) this device must accept any interference received, including interference that may cause undesired operation.

Any change to the antenna or the device could result in the device exceeding the RF exposure requirements and void user's right to operate the device.

WARNING CONSUMERS WITH PACEMAKERS

It is possible that the (optional) vibrating feature of this bed may be misinterpreted by some pacemakers as movement and/or exercise. This is common with any product that produces a vibrating motion, and may or may not affect your pacemaker. Please consult your physician with any concerns.

PRODUCT RATINGS

Lift Motor Restrictions: The lift motors in this bed are NOT designed to operate continuously for more than three (3) minutes over a thirty (30) minute time period, or approximately 10% duty cycle. To ensure reliable functionality and full life of this product, do not attempt to exceed these limits.

NOTE: *Attempting to circumvent or exceed this rating will shorten the life expectancy of the product and may void the warranty.*

The structure of the bed will support the recommended weight when distributed evenly across the bed. **The head and foot sections are not designed to individually support or lift this amount of weight.** For optimal performance, entering and exiting the adjustable bed with the bed in the flat or level position is recommended.

NOTE: *Exceeding the recommended weight restrictions could damage your adjustable bed and void your warranty.*

WARNING SMALL CHILDREN AND PETS WARNING

Immediately dispose of all packing materials as it can pose a smother risk to small children and pets. Injury could occur also if children or pets are permitted to play on or under the bed. Do not allow children to operate this bed without adult supervision.

SAVE THESE INSTRUCTIONS!

Proper operation of your Adjustable Bed is necessary to ensure the long life and durability you expect from a high-quality product. The manufacturer has tested and inspected this product prior to shipment.

Parts List

NOTE: Before discarding any packing materials, check the adjustable bed frame carton and verify all items in the parts list are included:



A. Remote Control (1)



B. Mattress Retainer Bracket (1)



C. Adjustable Bed Leg (6)**



D. Velcro Leg Strap (1) *



2 AAA Batteries

* Only in TXL, SCK, and SQ models

** QN, Twin, TXL, F, FXL, SQ, SCK models have 4 bed legs. K & CK have 6

Installation Guide

STEP 1. For safety reasons, the following should be performed by 2 people. Carefully lift the bed frame unit out of the shipping carton with the top side facing downward.

STEP 2. Open the accessories box, take out the legs (C), and thread them in a clockwise direction into the threaded holes in the frame. Adjust leg to desired height by twisting either clockwise or counter-clockwise.

ALL LEGS MUST BE ADJUSTED TO THE SAME HEIGHT

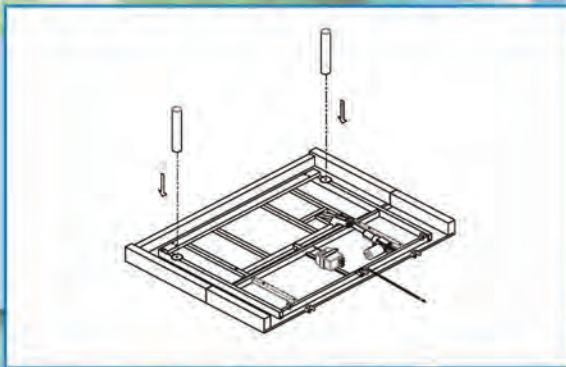

Head Section

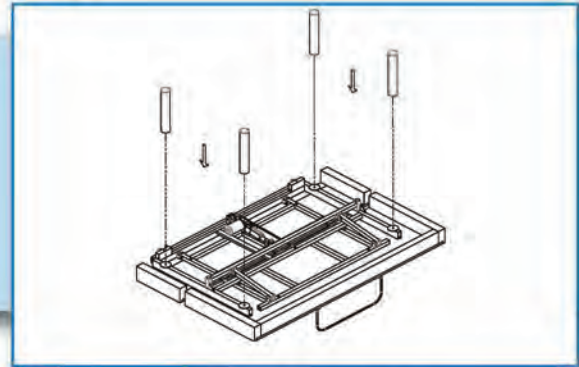

Foot Section

TIGHTEN THE LEGS SECURELY TO THE FRAME. DO NOT OVERTIGHTEN THE BED LEGS.

If the Clarity Adjustable Base is Not a King or a California King in Size, Please Skip Ahead to Step 5 Below.

STEP 3. Attaching the head & foot sections with the adjustable base in the upside down position, lift & place the foot section cleats (A) over the frame stem peg (B) on the head section and insert (B) into (A). Next insert steel pin (C) into the cleat hole to ensure stable assembly.

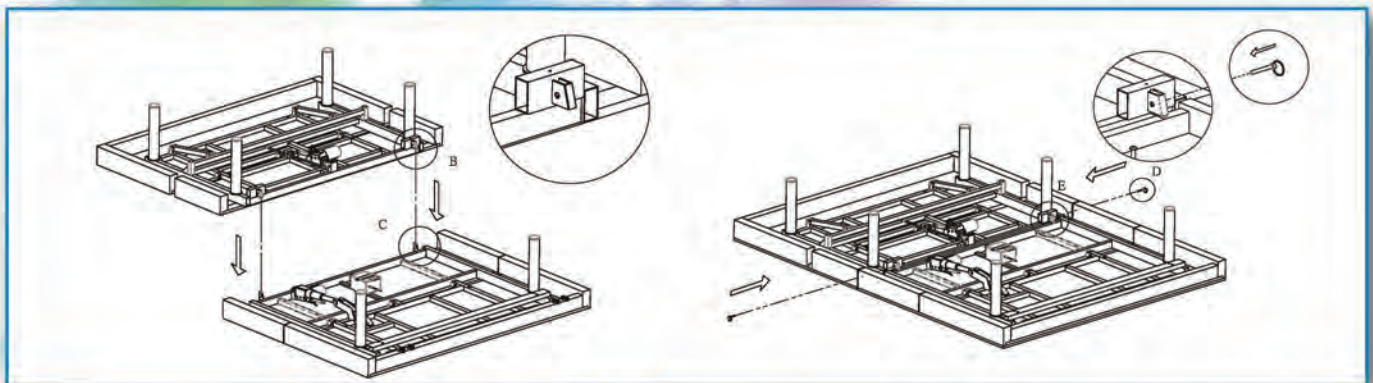

STEP 4. Insert the foot motor's red plug into the control box. Please refer to Figure A.

STEP 5. Remove and extend the power cord from the frame.

Important! MAKE SURE POWER CORDS DO NOT OBSTRUCT ANY ADJUSTABLE BED MECHANISMS.

NOTE: For optimal safety, a surge protector should be used (not supplied with this Adjustable Bed).

STEP 6. Take plastic wrapping off the base frame.

STEP 7. Carefully rotate the base frame over so the top side is facing upward. Be careful not to rest the frame on its side. The weight may damage the legs.

STEP 8. Plug the power cord into a grounded electrical outlet.

STEP 9. Install batteries in the remote control. If the remote control is a wired unit, no batteries are needed. Try all functions on the remote control to ensure all features are operational.

If the bed does not work, refer to Troubleshooting on page 8.

STEP 10. Return bed to flat or level position.



Figure A

Installation Guide

IMPORTANT NOTES:

Failure to follow the installation steps as they appear in this guide could result in damage to your adjustable bed frame. Make sure to position the bottom of the headboard cross member no more than 3 inches (76.2 mm) between the headboard and the top of the mattress.

This model does not include a headboard bracket kit. Headboard bracket kit can be purchased separately by contacting your authorized retailer

STEP 11. Attaching the "Quick-Slide" Mattress Retainer Bracket

Fasten the "Quick-Slide" mattress retainer bracket (B) to the foot of the bed base using the "Quick-Slide" Slide method illustrated below. (No tools or screws are required)

Simply position the open ends of the Retainer Bracket directly aligned with the "Loop" Retainer Anchors already installed to the foot of the base surface. Slide the Retainer Bracket forward allowing the open ends to glide into the loop.

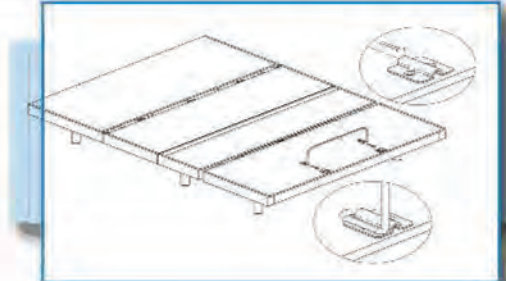

If A Headboard Is To Be Installed, Proceed to Step 12

STEP 12. Assembling the Headboard Bracket

NOTE: Make sure to attach the headboard bracket on the first round panels (1) under the head section of the bed. The second round panels (2) are for the bed legs.

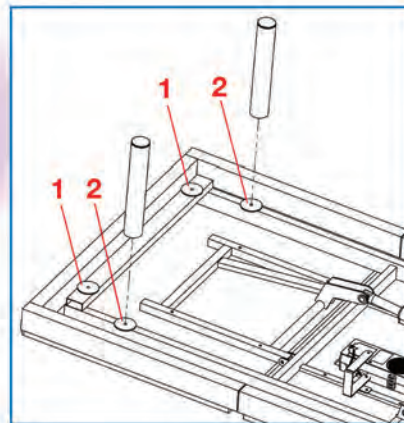

- i. Use the remote control to elevate the head of the bed so the bed base frame is reachable.
- ii. Position the inner headboard bracket (A) underneath the first round panel (1). (The bracket opening should face down under the bar.) Insert a 3/8 headboard bracket bolt (B) fitted with a 2.0t x 25mm washer (C) into the slot under the inner headboard bracket. Use the Allen Key wrench to tighten in place. Repeat on the other side.

For sizes Twin, Twin XL, Full, Full XL, Queen, Split Queen & Split CA King:

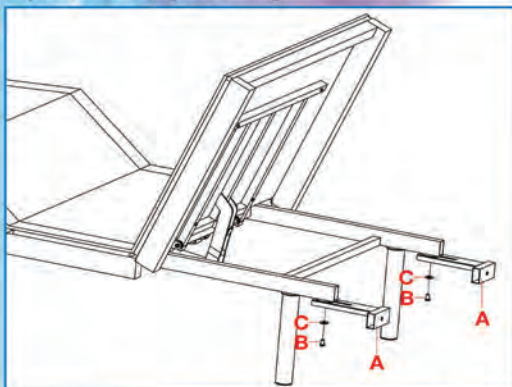

For sizes California King & King:

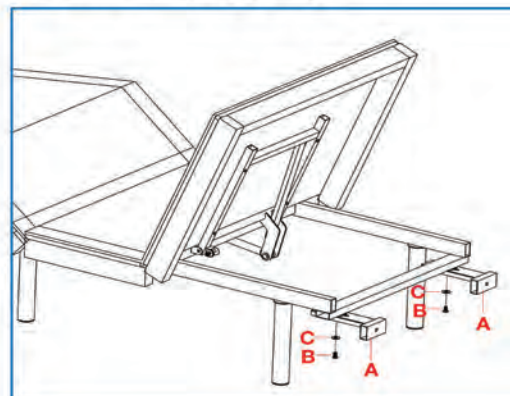

Installation Guide

IMPORTANT NOTES:

Failure to follow the installation steps as they appear in this guide could result in damage to your adjustable bed frame. Make sure to position the bottom of the headboard cross member no more than 3 inches (76.2 mm) between the headboard and the top of the mattress.

STEP 12. Assembling the Headboard Bracket (cont'd)

iii. Place the open side of the outer headboard bracket (D) onto the exposed square tube of the inner headboard bracket (A) to create a tight fit between (A) and (D). Insert a 5/16 headboard bracket bolt (E) fitted with a 1.5t x 16mm washer (F) into the outer headboard bracket (D) and through the inner headboard bracket (A). Use the Allen Key wrench to tighten in place. Repeat on the other side.

For sizes Twin, Twin XL, Full, Full XL, Queen, Split Queen & Split CA King:

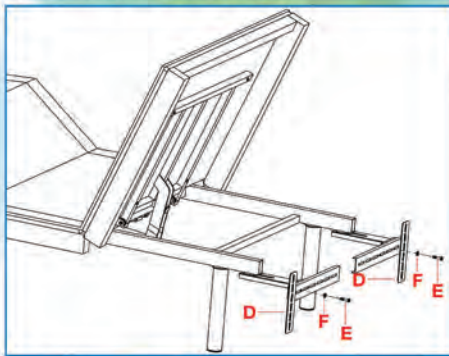

For sizes California King & King:

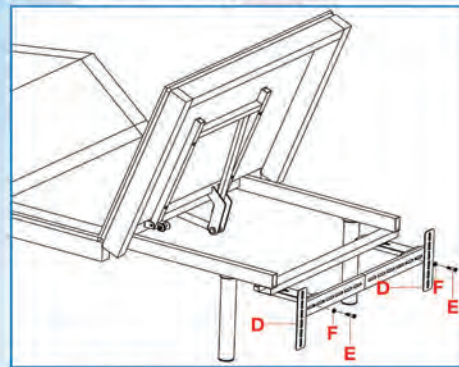

iv. When headboard brackets are assembled, make sure there is a space of 1.5 (38.1 mm) to 2 inches (50.8 mm) between the edge of the bed base and the headboard brackets.

v. Securely fasten the headboard bolts (not included with your adjustable bed) to the end of the headboard bracket assembly.

vi. Measure the distance from the center of one mounting hole in the headboard to the center of the other.

vii. Measure the distance from the center of one mounting hole in the headboard bracket assembly to the center of the other.

viii. If you need to adjust the headboard brackets, unscrew the bolts holding the outer headboard brackets and move them the necessary distance. Reinstall the bolts and securely tighten.

STEP 13.

Place your mattress on the adjustable bed frame surface. Your adjustable bed and headboard installation is now complete. If the bed comes with a programming option, refer to the Remote Control Operation Guide for more information.

Installing Velcro Leg Straps* (Optional: To avoid base separation)



* Only included with TXL, SCK, and SQ models.

To help prevent separation when using King Size (2 TXL), California King Size (2 SCK) or split Queen Size (2 SQ), use the enclosed Velcro Straps.

1. Wrap the legs together (Front & Back) tightly using the Velcro straps.
2. Fasten the straps together to help prevent movement & maintain stability.

Remote Control Operation Guide



Head and Foot Position Adjustments (A, B, C, D, E)

- Use to raise or lower the head and foot sections of your adjustable bed.

Safety Notice: The changes or modifications not expressly approved by the party responsible for compliance could void the user's authority to operate the equipment.

Important Note: To comply with the FCC RF exposure compliance requirements, no change to the antenna or the device is permitted. Any change to the antenna or the device could result in the device exceeding the RF exposure requirements and void user's authority to operate the device.

THIS DEVICE COMPLIES WITH PART 15 OF THE FCC RULES. OPERATION IS SUBJECT TO THE FOLLOWING TWO CONDITIONS: (1) THIS DEVICE MAY NOT CAUSE HARMFUL INTERFERENCE AND (2) THIS DEVICE MUST ACCEPT ANY INTERFERENCE RECEIVED, INCLUDING INTERFERENCE THAT MAY CAUSE UNDESIRE OPERATION.

FOR YOUR SAFETY, READ THE OWNER'S MANUAL CAREFULLY AND COMPLETELY BEFORE OPERATING THIS PRODUCT. ELECTRIC SHOCK MAY OCCUR IF ELECTRICAL COMPONENTS ARE NOT INSTALLED OR OPERATED ACCORDING TO THESE GUIDELINES.

Pairing Guide to Synchronize Two Beds

Your adjustable base is pre-programmed to your remote. However, to operate two adjustable bases together, you must pair both to one remote. Make sure your first adjustable base (Base A) is plugged in before focusing on your second adjustable base (Base B).

Please follow the steps below to complete the pairing:

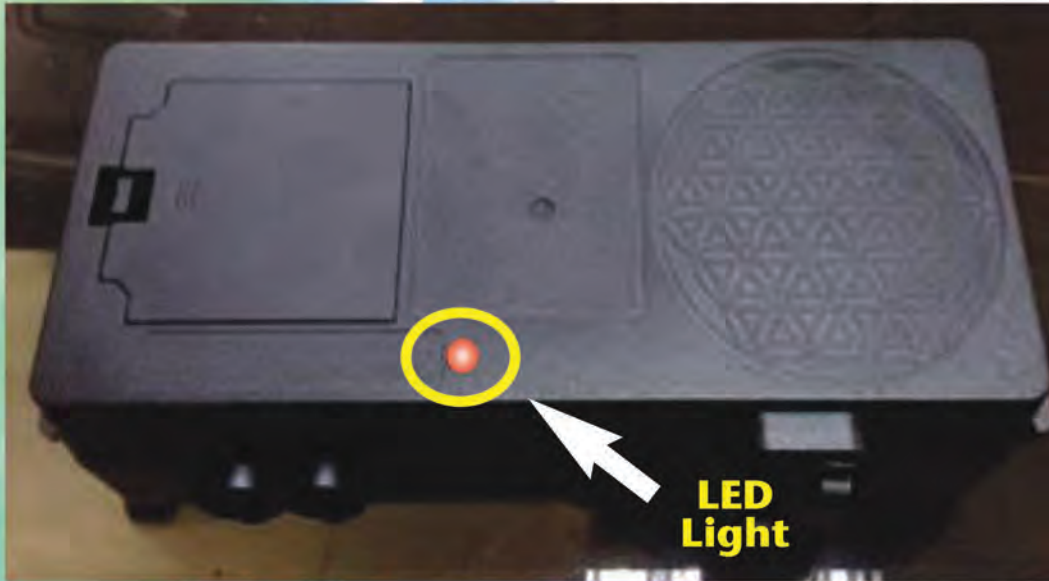

Step 1 - Plug in Base B to an AC power outlet (surge protector is recommended). Once plugged in, the LED light on the control box will blink three times, which indicates the control box has entered Learning Mode. Learning Mode lasts seven seconds.

Step 2 - During Learning Mode, use Remote A to press the "Head Up" and "Foot Up" keys together for three seconds.

Step 3 - The LED light on the control box will light up and remain on, which means the pairing is successful.

Now Base A & B will function with Remote A and the pairing of the two adjustable bases is complete.

To Reset Your Pre-Programmed Remote:

Step 1 - Unplug the AC power.

Step 2 - Press and hold the FLAT button (without release) to continue sending signal.

Step 3 - Plug in the AC power and wait for 7 seconds, then release the FLAT button. (Please Note: The control box must receive FLAT signal from the remote for at least 5 seconds after the AC power is plugged back in).

Step 4 - The reset is complete.



Troubleshooting

In the event the adjustable bed fails to operate, investigate the symptoms and possible solutions provided in the chart below:

SYMPTOM

SOLUTION

Remote control LED illuminates and appears Normal, but will not operate bed.

- 1) Is the power cord plugged into a working & grounded electrical outlet?
 - **NOTE:** A grounded, electrical surge protection device is recommended (not supplied)
- 2) Test outlet by plugging in an appliance you know works properly.

None of the Functions on the Adjustable Bed will Operate.

- 1) Unplug the power cord. After 45 seconds, plug in to electrical outlet. This should reset the electronic components.
- 2) The Home Electrical circuit breaker may have been tripped. Reset circuit breaker if needed.
- 3) Check surge protection device or electrical outlet to insure working order. Test outlet by plugging in a known working appliance.

Head or foot section Function Key will elevate bed, but will not return to the horizontal (Flat) position.

- 1) Your Bed may be obstructed preventing smooth operation. Remove obstructions from around & under the bed.
- 2) Check that Head section has clearance from headboard or wall.
- 3) Headboard may be too close the edge of the mattress. Verify a 1.5" (38.1mm) to 2" (50.8mm) distance between headboard brackets and mattress. Adjust if required.

IF YOU EXPERIENCE ANY TROUBLE WITH YOUR BED FRAME WITHIN THE WARRANTY PERIOD, PLEASE CONSULT THE TROUBLESHOOTING GUIDE PROVIDED WITH YOUR FRAME AND ONLINE (IF APPLICABLE). IF PROBLEMS PERSIST, PLEASE CALL:

**CUSTOMER SERVICE TOLL FREE NUMBER
1-843-800-8372**

Please Have Your Receipt Ready And Available

THANK YOU AND ENJOY YOUR ADJUSTABLE BED FRAME!

WARRANTY

20-Year Basic Limited Warranty for Adjustable Bed Frames

CUSTOMATIC ADJUSTABLE BEDZ[®] ("CUSTOMATIC ADJUSTABLE BEDZ") warrants this motorized bed frame or motorized bed foundation (hereinafter referred to as "adjustable bed" or "adjustable beds") to the consumer who is the original purchaser (the "purchaser," subject to the terms and conditions set forth herein). This warranty begins on the "warranty commencement date" which is the date of purchase for new unused adjustable beds and the date of manufacture for adjustable beds that have been used as floor or display models. Thus, on a floor model adjustable bed, the warranty is a portion of the limited 20-year warranty. If original proof of purchase is not provided by purchaser, CUSTOMATIC ADJUSTABLE BEDZ[®] reserves the right to determine the adjustable bed is not covered by this warranty or to use the manufacturing date as the warranty commencement date. This "Limited Warranty for Adjustable Beds" ("Limited Warranty," "limited warranty," "warranty") extends only to the original purchaser and may not be transferred.

FULL 1-YEAR WARRANTY

This adjustable bed is warranted against defects in the workmanship or materials for a period of up to one (1) year from the warranty commencement date. Upon receiving reasonable notice during the first year from the warranty commencement date, CUSTOMATIC ADJUSTABLE BEDZ[®] will send replacement parts (at no cost to the purchaser) for any defective adjustable bed part to the purchaser, and CUSTOMATIC ADJUSTABLE BEDZ[®] will pay all pre-authorized labor and transportation costs associated with the repair or replacement of any parts CUSTOMATIC ADJUSTABLE BEDZ[®] determines to be defective. This one (1) year warranty shall not apply if purchaser does not return any and all defective parts to CUSTOMATIC ADJUSTABLE BEDZ[®] within 15 days of purchaser's receipt of replacement part(s).

19-YEAR LIMITED WARRANTY

Upon receiving reasonable written notice at any time after 1 year and up to twenty years from the warranty commencement date, CUSTOMATIC ADJUSTABLE BEDZ[®] will offer replacement parts (upon terms and conditions set forth in this paragraph) for any mechanical bed part found to be defective. Electronics, electrical components, drive motors and massage motors are excluded. Purchaser shall pay 18/19th of the then current replacement cost of the defective part. Any consumer of an CUSTOMATIC ADJUSTABLE BEDZ[®] adjustable bed shall bear the remainder of the cost of the replacement part. This nineteen (19) year warranty shall not apply if purchaser does not return any and all defective parts to CUSTOMATIC ADJUSTABLE BEDZ[®] within 15 days of purchaser's receipt of replacement part. In those cases where the nineteen (19) year warranty applies, the purchaser shall bear all service, transportation, labor, and shipping costs related to the delivery and/or replacement of the defective part. With respect to adjustable beds that are more than twenty (20) years after the warranty commencement date, the purchaser shall bear the entire cost of repair and replacement of all parts and materials, including labor and transportation.

ADDITIONAL TERMS AND CONDITIONS

This warranty does not apply; (a) to any damage caused by the purchaser; (b) if there has been any unauthorized repair or replacement of adjustable bed parts; (c) if the adjustable bed has been mishandled (whether in transit or by other means), subjected to physical or electrical abuse or misuse, or otherwise operated in any way inconsistent with the operation and maintenance procedures outlined in the Owner's Manual, this warranty, and any other applicable document published or approved by CUSTOMATIC ADJUSTABLE BEDZ[®]; (d) to damage to mattresses, fabric, cables, electrical cords or items supplied by dealers. Contact the dealer or relevant party for warranty information on these items.; (e) if there has been any unnecessary service calls, including costs for in-home service calls solely for the purpose of educating the consumer about the adjustable bed for finding an unsatisfactory power connection; (g) if the recommended weight restrictions are not followed (Twin/TXL/Split QN/Split CA King: 700 pounds, King/CA King/QN/Full/FXL: 850 pounds), the warranty will be void.

Repairs to or replacement of the adjustable bed or its components under the terms of this limited warranty will apply to the original warranty period and will not serve to extend such period.

The decision for the repair or replacement of defective parts under this warranty is at the option and sole discretion of CUSTOMATIC ADJUSTABLE BEDZ[®].



REPAIR OR REPLACEMENT OF ADJUSTABLE BED PARTS WILL BE THE SOLE REMEDY OF THE PURCHASER. CUSTOMATIC ADJUSTABLE BEDZ[®], AND THEIR PARENTS, SUBSIDIARIES, DIVISIONS, AFFILIATES OR AGENTS HOLD ABSOLUTELY NO LIABILITY OR ANY SPECIAL, INDIRECT, INCIDENTAL, OR CONSEQUENTIAL DAMAGES OR FOR ANY OTHER DAMAGE, CLAIM, OR LOSS NOT EXPRESSLY COVERED BY THE TERMS OF THIS WARRANTY.

WARRANTY

No reimbursement will be made to the purchaser for inconvenience, removal, installation, setup time, lack of use, shipping, or any other costs or expenses not covered by this warranty. CUSTOMATIC ADJUSTABLE BEDZ® does not hold responsibility for in-home service on adjustable beds. You must contact your dealer or party that sold the adjustable bed for any terms and conditions relating to their in-home service, should any exist.

CUSTOMATIC ADJUSTABLE BEDZ®, AND THEIR PARENTS, SUBSIDIARIES, DIVISIONS, AFFILIATES OR AGENTS MAKE NO OTHER WARRANTY WHATSOEVER, EXPRESS OR IMPLIED. ALL IMPLIED WARRANTIES OF MERCHANTABILITY AND FITNESS FOR A PARTICULAR PURPOSE ARE DISCLAIMED BY NAME AND EXCLUDED FROM THIS AGREEMENT.

The above limitation or exclusion may not apply to every purchaser as some states disallow exclusions or limitations of incidental or consequential damages. This warranty allows the purchaser specific legal rights. The purchaser may also have other rights, which can vary from state to state. This warranty is valid in the contiguous United States, and includes Alaska, Puerto Rico and Canada.

 WARRANTY REGISTRATION FORM	
r i z e by  CUSTOMATIC*	SURVEY
Name _____	Gender: ___ M ___ F
Phone _____	Age: ___ 20-30 ___ 31-40 ___ 41-50 ___ 51-60 ___ 61-70 ___ 71 & up
Address _____	Reason for purchasing an adjustable bed: ___ Health ___ Comfort ___ Other
Address _____	How did you find out about CUSTOMATIC Bedz: ___ Advertising ___ A friend ___ Store ___ Article/Review ___ Internet ___ Other
City _____	
State _____ Zip _____	
Email _____	
Store where purchased _____	PLEASE MAIL TO: CUSTOMATIC Adjustable Bedz® Customer Care Center 550 Crescent Blvd., Gloucester City, NJ 08030
Bed Serial No. _____	
Bed Model No. _____	
Invoice No. _____	

Visit www.rizebeds.com to complete your Rize Warranty Registration online.



The
CLARITY
Adjustable Bed Frame



**IF YOU EXPERIENCE ANY TROUBLE WITH YOUR BED FRAME WITHIN THE WARRANTY PERIOD,
PLEASE CONSULT THE TROUBLESHOOTING GUIDE PROVIDED WITH YOUR FRAME
AND ONLINE (IF APPLICABLE). IF PROBLEMS PERSIST, PLEASE CALL:**

**CUSTOMER SERVICE TOLL FREE NUMBER
1-843-800-8372**

Please Have Your Receipt Ready And Available

THANK YOU AND ENJOY YOUR ADJUSTABLE BED FRAME!